

**ELECTROMAGNETIC BACKGROUND TESTS FOR THE ILC  
INTERACTION-POINT FEEDBACK SYSTEM**

P.N. Burrows, G. Christian, C. Clarke, B. Constance, H. Dabiri Khah, T. Hartin, C. Perry,  
C. Swinson, John Adams Institute, Oxford University, UK; A. Kalinin, Daresbury  
Laboratory, UK  
R. Arnold, S. Molloy, S. Smith, G.R. White, M. Woods, SLAC, USA.

## ELECTROMAGNETIC BACKGROUND TESTS FOR THE ILC INTERACTION-POINT FEEDBACK SYSTEM

P.N. Burrows, G. Christian, C. Clarke, B. Constance, H. Dabiri Khah, T. Hartin, C. Perry,  
C. Swinson, John Adams Institute, Oxford University, UK; A. Kalinin, Daresbury Laboratory, UK  
R. Arnold, S. Molloy, S. Smith, G.R. White, M. Woods, SLAC, USA.

### Abstract

We present results obtained with the T-488 experiment at SLAC Endstation A (ESA). A material model of the ILC extraction-line design was assembled and installed in ESA. The module includes materials representing the mask, beamline calorimeter, and first extraction quadrupole, encompassing a stripline interaction-point feedback system beam position monitor (BPM). The SLAC high-energy electron beam was used to irradiate the module in order to mimic the electromagnetic (EM) backgrounds expected in the ILC interaction region. The impact upon the performance of the feedback BPM was measured, and compared with detailed simulations of its expected response.

### INTRODUCTION

The achievement of design luminosity at the International Linear Collider (ILC) [1] will depend critically on a fast beam-based feedback (FB) correction for maintaining collisions [2]. Ground-motion and facilities noise effects will cause position/angle offsets at the interaction point (IP) between each incoming electron and positron bunchtrain. Because of the nanometre-scale vertical bunch sizes the luminosity performance is most susceptible to relative position/angle offsets in the vertical plane, which are hence most critical to correct. In order to be effective at luminosity recovery the feedback needs to operate on a bunch-by-bunch timescale within each bunchtrain.

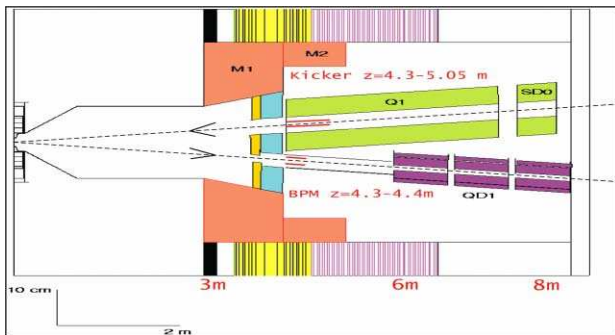

Figure 1: Schematic of ILC interaction region showing possible locations of the kicker and BPM.

The position feedback concept is shown schematically in Figure 1. Transverse position offsets between each incoming electron and positron bunch induce a large transverse deflection of the outgoing beams. This beam-beam deflection signal can be measured in a beam

position monitor (BPM) located downstream of the IP. The BPM signal can be processed to infer the beam-beam offset at the IP, and used to drive an amplifier to provide a fast correction via a kicker located on the incoming beamline just upstream of the IP [2].

However, the beam-beam interaction also yields copious backgrounds of  $e^+e^-$  pairs and photons. The numbers of primary  $e^+e^-$  particles produced are summarised for various ILC parameter sets in Table 1. For example, the 500 GeV parameter ‘scheme 1’ yields c. 200,000 pair particles *per bunch crossing*, and the 1 TeV high-luminosity ‘scheme 14’ yields c. 700,000. The average pair-particle energy is also shown in Table 1: it is typically around 10-15 GeV.

Table 1: Number of primary  $e^+e^-$  pair particles produced in beam-beam interactions, their average energy, and the corresponding number of hits at the IP FB BPM vs. machine parameter set. Schemes 1-7 (7-14) are for 500 (1000) GeV c.m. energy.

Beam Parameters Scheme	Number of Pair Particles	Average Energy (GeV)	BPM hits
Scheme 1	195652	10.8	5141
Scheme 2	164370	10.6289	4497
Scheme 3	121966	10.8947	3057
Scheme 4	49720	12.3421	1074
Scheme 5	124273	9.58301	2321
Scheme 6	272218	10.6636	9686
Scheme 7	320352	10.9809	12314
Scheme 8	193166	11.2826	5127
Scheme 9	237749	11.5317	8758
Scheme 10	192976	11.3083	6399
Scheme 11	85218	12.8034	2623
Scheme 12	247683	10.1212	9287
Scheme 13	500457	13.8549	25016
Scheme 14	678811	15.5845	80443

In the high B-field of the detector solenoid these pair particles typically spiral around the solenoid field lines. Some will strike the downstream mask and forward calorimeters, or the first magnet in the extraction line, (Figure 2), to produce EM showers that cause secondary pairs and photons to hit the feedback BPM.

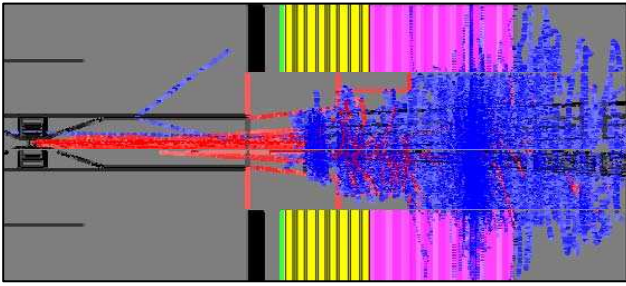

Figure 2: Example of primary e+e- pair particles striking forward-region elements and causing secondary EM showers in the vicinity of the IP feedback BPM.

We have simulated the interaction of the primary pair flux with the IR material to derive an estimate of the count of secondary pair hits on the BPM strips, Table 1. The number of hits per bunch crossing ranges between a few thousand and c. 80,000 (scheme 14). The total energy deposited per strip per bunch crossing can be as large as 1000 GeV. The impact of these hits on the BPM performance is a priori uncertain.

### T488 EXPERIMENT AT ESA

We studied the performance of an ILC-style FB BPM in a realistic EM background environment that was created using the 28.5 GeV electron beam at SLAC's Endstation A (ESA). The experiment was assigned test-beam number T488. A material model of the ILC extraction line was designed (Figure 3) to incorporate the relevant material elements: the front face of the mask, the beamline calorimeter, the FB BPM, and the first magnet. In each case material of the relevant density and transverse dimensions was incorporated into a module (Figure 4) that was inserted into the beamline at ESA. The beam was used in two modes in order to create an ILC-like environment of secondary hits at the BPM strips.

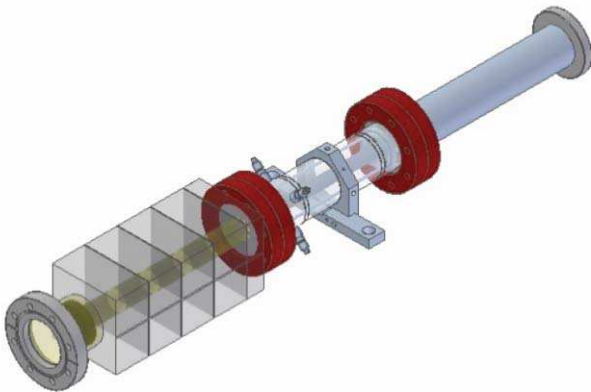

Figure 3: T488 module design showing (left to right) material mockup of the mask, beamline calorimeter, BPM, and magnet.

In the first beam run the A-line optics was tuned so as to produce a large beam spot, roughly 1mm in transverse dimensions, in ESA. With this large spot the bunch

charge was varied in the range  $10^6$  to  $10^8$  electrons, and in each case the beam was steered onto the front face of the module. The BPM stripline signals were monitored in order to observe the effect of secondary hits on the signal shapes.

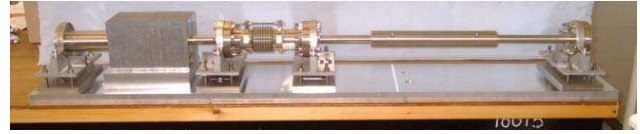

Figure 4: T488 module prior to beamline installation.

An example is shown in Figure 5. When the beam was steered into the module noticeable degradation of the BPM signals was observed, especially for those striplines *opposite* the beam, indicating a sizeable contribution from noise hits due to secondary EM spray. We developed a simple model of the production of noise in the striplines due to bombardment by EM shower secondaries. The model reproduces the features seen in Figure 5 [3].

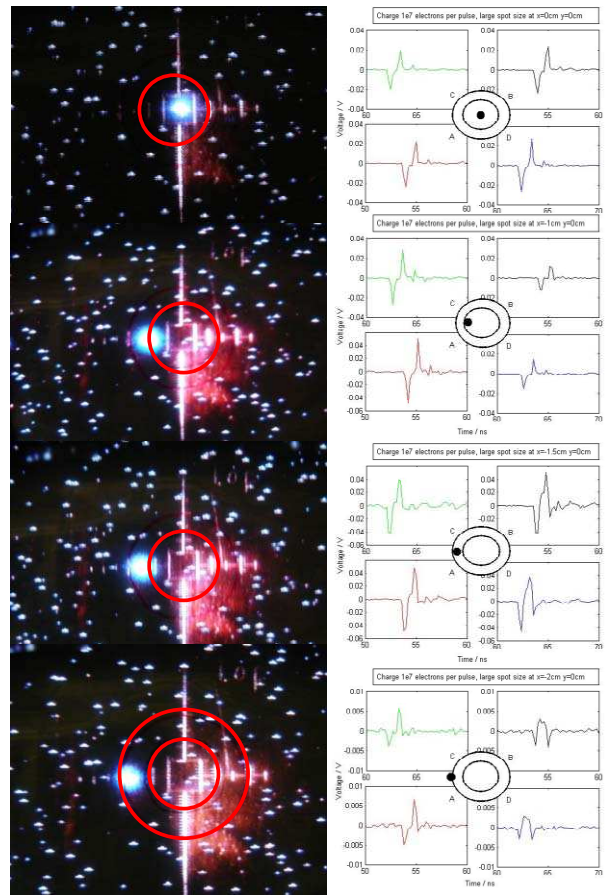

Figure 5: ESA beam scan across the front face of the T488 module. Left: beam imaged on a screen, with the module extent indicated by the red circles. Right: corresponding BPM stripline signals.

In the second beam run the high-energy beam, with nominal optics and bunch charge ( $1-2 \times 10^{10}$  e-) was

passed through a thin radiator upstream of the T488 module so as to create a halo of secondary particles that accompanied the primary beam. In this mode we were able to create both a primary beam signal in the BPM and a halo that modelled the ILC pair flux at the front face of the mask in the T488 module. Tungsten radiators corresponding to 1%, 3% and 5% radiation lengths were used sequentially in order to vary the halo population.

As an example, Figure 6 shows a simulation of the number of BPM hits generated by such a halo, for the case of a 5% radiator. Shown for comparison are BPM hit numbers at ILC, for scheme 14, for 20mrad and 14mrad crossing angles. Up to  $10^8$  hits per strip can be produced at ESA, which is 2-3 orders of magnitude larger than the number expected at ILC. Corresponding results for the total energy incident upon the strips are shown in Figure 7. The scale factor between T488 and ILC is again roughly 3 orders of magnitude.

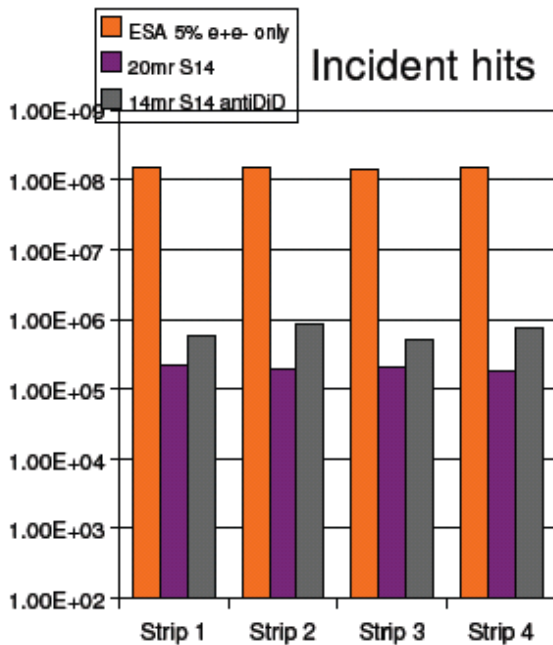

Figure 6: Total incident hits on each BPM strip for strips at horizontal and vertical locations in the IP FB BPM: ILC scheme 14: 20mrad crossing (purple), 14mrad (grey); ESA with 5% radiator (orange).

We compared both the raw BPM stripline signals and the output of the FONT4 BPM processor [2] for beam runs without, and with, the thin radiator in place. As an example the peak of the BPM processor output signal is shown in Figure 8. It is the equivalent of this signal that would be sampled to provide the position input to the IP FB at ILC [2]. The peak voltage with 5% radiator (worst case) is  $0.102 \pm 0.005V$ ; bracketing runs without the radiator yield  $0.105 \pm 0.002V$  and  $0.103 \pm 0.002V$ . Therefore within the statistical errors we see no evidence of any impact of EM noise hits on the BPM performance even in a background environment roughly 1000 times worse than that expected at ILC. We conclude that the

ILC IP FB BPM design and planned location are robust with respect to EM backgrounds.

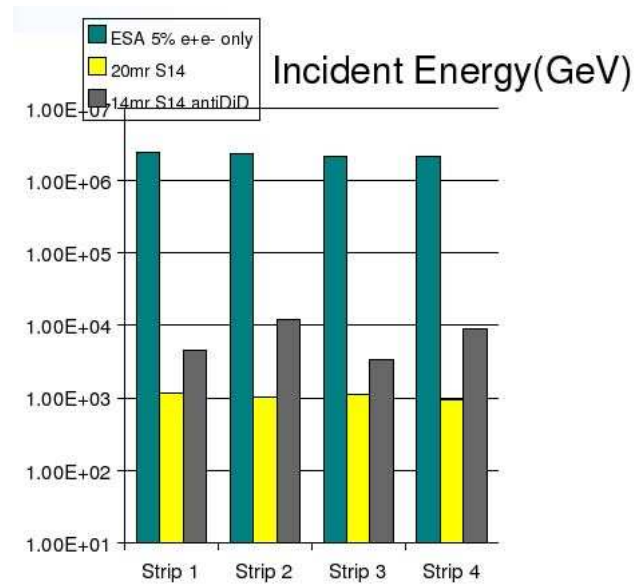

Figure 7: As Figure 6, for total incident energy.

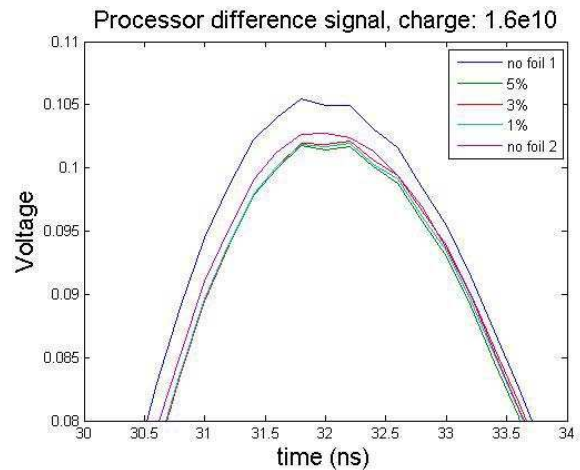

Figure 8: FONT BPM processor output near the signal peak for beam runs without, and with, thin radiators in place. Each curve is the average over 1000 beam pulses.

### ACKNOWLEDGEMENTS

This work is supported by the Commission of the European Communities under the 6th Framework Programme "Structuring the European Research Area", contract number RIDS-011899, and by the UK Science and Technology Facilities Council.

### REFERENCES

- [1] ILC: <http://www.linearcollider.org/cms/>
- [2] FONT4: P.N. Burrows et al, these proceedings.
- [3] A. Hartin, these proceedings.