

THE CONCEPTUAL DESIGN OF 4GLS AT DARESBUURY LABORATORY

J. A. Clarke, CCLRC Daresbury Laboratory, Warrington, UK, on behalf of the 4GLS Design Team.

Abstract

4GLS is a novel next generation proposal for a UK national light source to be sited at Daresbury Laboratory, based on a superconducting energy recovery linac with both high average current photon sources (undulators and bending magnets) and three high peak current free electron lasers. Key features are a high gain, seeded FEL amplifier to generate XUV radiation and the prospect of advanced research arising from unique combinations of sources with femtosecond pulse structure. The conceptual design is now completed and a CDR recently published.

THE CONCEPTUAL DESIGN OF 4GLS AT DARESBUARY LABORATORY

J. A. Clarke, CCLRC Daresbury Laboratory, Warrington, UK, on behalf of the 4GLS Design Team.

Abstract

4GLS is a novel next generation proposal for a UK national light source to be sited at Daresbury Laboratory, based on a superconducting energy recovery linac with both high average current photon sources (undulators and bending magnets) and three high peak current free electron lasers. Key features are a high gain, seeded FEL amplifier to generate XUV radiation and the prospect of advanced research arising from unique combinations of sources with femtosecond pulse structure. The conceptual design is now completed and a CDR recently published [1].

INTRODUCTION

4GLS will enable the study of real time molecular processes and reactions on timescales down to tens of femtoseconds in short-lived, nano-structured or ultra-dilute systems. The emphasis is on molecular and device function, rather than the largely ‘static’ structural focus of work on 3rd generation synchrotron radiation sources and X-ray FELs.

The 4GLS facility is planned from the outset to be a multi-source, multi-user facility. This is achieved by superconducting radio-frequency accelerator technology, operating using energy recovery, to provide short pulse spontaneous radiation with pulse length variable from ps to < 100 fs. At long wavelengths this allows the condition for coherent synchrotron radiation production to be met, with the result that 4GLS will provide enormously bright THz radiation. The high quality low emittance electron beam provided by the linacs additionally provides an

ideal source with which to operate free electron lasers (FELs). In the 4GLS conceptual design [1] these are embedded within the facility, delivering ultra-high brightness short-pulse radiation in the IR, VUV and XUV energy ranges, with pulse lengths as short as 50 fs FWHM. In world terms, this gives a unique suite of synchrotron radiation (SR) and FEL sources covering the THz to the soft X-ray range. Many of the light pulses originate from the same electron bunch, thus offering potential levels of internal synchronization at the tens of femtoseconds level. The peak brightness of the 4GLS sources is given in figure 1. There is a typical enhancement of eight orders of magnitude when compared with 3rd generation light sources.

Significant aspects of the 4GLS design have been informed by experience gained on the 4GLS Energy Recovery Linac Prototype (ERLP) currently approaching completion at CCLRC Daresbury Laboratory [2, 3].

OVERVIEW

4GLS consists of three inter-related accelerator systems [12] (see figure 2). The first is the high average current loop (HACL). In this a 600 MeV beam of 77 pC bunches is delivered at repetition rates of up to 1.3 GHz and energy recovery is an essential element. Progressive compression of the electron bunches in this loop allows for photon pulse lengths from a few ps to approximately 100 fs (RMS). The VUV FEL is placed towards the end of the HACL.

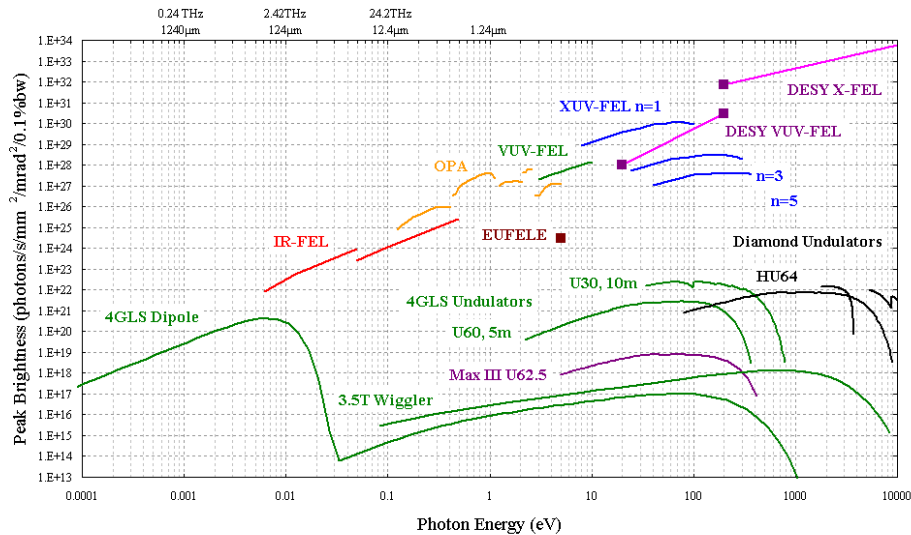

Figure 1. Peak brightness for 4GLS FELs, undulators, wiggler, OPA and dipoles compared with EUFELE, X-FEL, Diamond and Max III undulators.

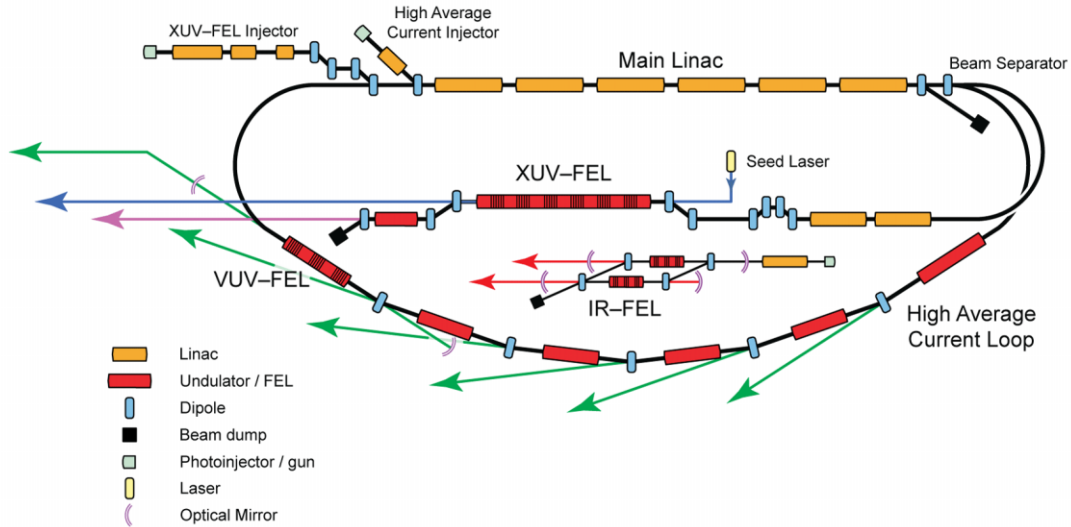

Figure 2. The conceptual layout of 4GLS.

Table 1. Main electron beam parameters of 4GLS

<i>Bunch Parameter</i>	<i>XUV-FEL</i>	<i>100 mA HACL</i>	<i>VUV-FEL HACL</i>	<i>IR-FEL</i>
		<i>Operation</i>	<i>Operation</i>	
Electron Energy	750 to 950 MeV	600 MeV	600 MeV	25 to 60 MeV
Normalised Emittance	2 mm mrad	2 mm mrad	2 mm mrad	10 mm mrad
RMS Projected Energy Spread	0.1 %	0.1 %	0.1 %	0.1 %
RMS Bunch Length	< 270 fs	100 to 900 fs	100 fs	1 to 10 ps
Bunch Charge	1 nC	77 pC	77 pC	200 pC
Bunch Repetition Rate	1 kHz	1.3 GHz	n x 4.33 MHz	13 MHz
Electron Beam Average Power	1 kW	60 MW	n x 200 kW	156 kW

The second major accelerator system is the XUV-FEL branch. The XUV-FEL requires a peak current of ~ 1.5 kA at beam energies from 750 to 950 MeV. This beam is derived from 1 nC bunches produced by a normal conducting RF photo injector operating at 1 kHz. At this repetition rate the 1 kW of beam can be safely dumped after traversing a final spontaneous undulator source.

Although the XUV-FEL beam and the high average-current beam discussed above are derived from separate electron sources after suitable low energy acceleration they are merged and accelerated in a single superconducting linac. The two beams are then separated using magnetic, energy separation for delivery to their respective devices.

The third accelerator system is that required for the IR-FEL. The same linac technology is used to accelerate electrons to between 25 and 60 MeV to provide a fully integrated and synchronised IR-FEL facility. The main electron beam parameters for 4GLS are given in Table 1.

The 4GLS design utilises superconducting linacs to accelerate and manipulate the three beams required to drive the photon sources. The accelerating structures are all based on a fundamental RF frequency of 1.3 GHz and

a modified TESLA type cavity design operating at 2 K or below [4, 5]. A prototype 2 cavity cryomodule is currently being developed at Daresbury Laboratory [6].

The most challenging area of accelerator design for 4GLS is in meeting the requirements of extremely high peak current for the XUV-FEL branch whilst simultaneously transporting and accelerating very high quality high-average current (100 mA) beam to the energy recovery loop.

The bunches within both of these beams have to undergo a significant amount of compression to deliver the required peak currents to drive the XUV- and VUV-FELs and to meet the requirements of the science case for different pulse lengths from undulators in the HACL. An innovative, integrated acceleration and compression scheme is proposed which meets the unique requirements for each of the two beams whilst using the same main superconducting accelerator [7]. By defining appropriate accelerating phases within the linacs, the high compression demands of the XUV-FEL are met using a two-stage compression scheme including a higher harmonic RF system for flexible non-linear correction, whilst progressive compression through the undulator arc

delivers the high peak current in the 77 pC bunches required to drive the VUV-FEL. Wakefield effects in the accelerator are reduced by performing the final compression stage at full energy so that the bunches around the arcs are kept relatively long to control the disruptive effects of coherent synchrotron radiation emission. Acceleration of a 100 mA beam is very challenging; to accelerate and decelerate such a beam requires that the linac transport design is tailored to give a high threshold for the disruptive beam break-up instability. This is achieved through a combination of techniques including substantial damping of HOMs in an advanced design of RF cavity, tight control of beam focussing throughout the linac and optimisation of coupling and overall transport properties in the energy recovery loop [8, 9].

A simple yet robust seeded design for the XUV-FEL is proposed [10] to ensure that ultra-high quality, reproducible, tunable radiation is available in the 8 to 100 eV photon range. The output pulses will have selectable polarisation and a pulse repetition rate of 1 kHz is set by the seed laser and the photoinjector; upgrade paths to 10 kHz for both these items looks likely. Established FEL theory and state-of-the-art simulation codes predict this FEL will generate photon energies at multi giga-watt power levels in pulses of duration ~ 50 fs FWHM. The pulses will have excellent temporal and spatial coherence with time-bandwidth products close to the Fourier transform limit for a Gaussian pulse. Unlike the self amplified spontaneous emission mode of operation, which effectively self-starts from intrinsic noise, the FEL interaction here is acting as a true amplifier. The high quality spectral properties of the radiation input seed pulses are maintained by the amplified output radiation pulses. Recent advances in High Harmonic Generation sources mean that the seed requirements for the XUV-FEL already exist.

The VUV-FEL offers high repetition rates (multiples of 4.33 MHz) with giga-watt peak power and > 100 W average power [11]. Here advantage is taken of mirrors (with hole out-coupling) that are able to operate over the photon energy range of 3 to 10 eV. Photon pulse lengths of ~ 170 fs (FWHM) will be obtained in standard mode and simulations suggest that pulses as short as ~ 25 fs may be possible in a super-radiant mode. The output pulses will have selectable polarisation and be fully tunable.

By using a pair of mirrors to reflect light emitted by the FEL back to the entrance of the device it becomes, in effect, self-seeding and no external conventional laser system is required. Hence high quality, stable light is ensured through a rather simple optical feedback loop. A particular feature of this FEL when compared with similar designs covering the same wavelength range is the tolerance to low mirror reflectivity. Extensive simulations have shown that mirror reflectivities in the range 40 to 60 % are acceptable for this design. Detailed modelling has been used to confirm excellent spatial and temporal coherence and a regime has been identified where the

performance of the device is relatively insensitive to (and can even be enhanced by) degradation of mirror reflectivity.

The IR-FEL has been designed to produce high intensity, spatially and temporally coherent radiation with variable pulse lengths, flexible output pulse patterns and variable polarisation over the wavelength range 2.5 to 200 μm . The high-Q cavity-based design employs two undulators and hence offers the potential to satisfy user experiments at two different wavelengths simultaneously. The provision of short electron bunches offers the potential to operate the FEL in super-radiant mode to produce shorter pulses with higher peak intensities than available in normal operation: simulations predict FWHM pulse lengths of only a few optical cycles can be produced in this way. The implementation of a superconducting RF linac with the IR-FEL will offer highly stable operation and also high average powers (> 100 W) though the option of running in modes that reduce the average power for sensitive samples will also be available.

There are six insertion device straights in the HACL, one of which is allocated to the VUV-FEL. The remaining five will be used to generate spontaneous radiation. To maximise the potential of the spontaneous sources three different undulator straight lengths have been chosen; two 14 m straights; two 10 m straights and two 8 m straights. Thus the total space available for undulators is ~ 64 m, which exceeds all other existing low energy 3rd generation light sources.

REFERENCES

- [1] 4GLS Conceptual Design Report 2006, available from www.4gls.ac.uk
- [2] S. L. Smith et al, 'The Status of the Daresbury Energy Recovery Prototype Project', these proc.
- [3] S. L. Smith, 'A Review of ERL Prototype Experience and Light Source Design Challenges', these proc.
- [4] P. A. McIntosh et al, 'RF Requirements for the 4GLS LINAC Systems', these proc.
- [5] S. Pattalwar et al, 'Key Cryogenics Challenges in the Development of the 4GLS', these proc.
- [6] P. A. McIntosh et al, 'Development of a Prototype Superconducting CW Cavity and Cryomodule for Energy Recovery', these proc.
- [7] B. D. Muratori et al, 'Lattice Design for the Fourth Generation Light Source at Daresbury Laboratory', these proc.
- [8] E. Wooldridge and B. D. Muratori, 'Linac Focusing and Beam Break Up for 4GLS', these proc.
- [9] E. Wooldridge, 'Alternate Cavity Designs to Reduce BBU', these proc.
- [10] B. W. J. McNeil et al, 'Design Considerations for the 4GLS XUV-FEL', FEL 2005.
- [11] N. Thompson et al, 'A VUV-FEL for 4GLS: Design Concept and Simulation Results', FEL 2005.
- [12] M. W. Poole and E. A. Seddon, '4GLS and the Energy Recovery Linac Prototype Project at Daresbury Laboratory', PAC 05, Knoxville, p431.